



1-800-443-4859

# 5300 Series Installation Guidelines



## **WARNING:**

**RISK OF ELECTRICAL SHOCK OR BURNS.**

**THIS CONVERTER ASSEMBLY SHOULD BE INSTALLED BY A QUALIFIED ELECTRICIAN OR CERTIFIED RV TECHNICIAN.**

**IMPROPER INSTALLATION OR CONNECTION COULD CAUSE SERIOUS INJURY OR DEATH. NO ENDORSEMENT OF TECHNICAL EXPERTISE IS EITHER EXPRESSED OR IMPLIED.**

Electrical installation shall comply with the standards and safety requirements of the ANSI/RVIA 12V Standard for Low Voltage Systems in Conversion and Recreational Vehicles, NFPA 70 National Electrical Code and the NFPA 1192 Standard for Recreational Vehicles.

Property Parallax Group Inc.. All rights reserved. Refer installation and servicing to qualified service personnel. **Service information provided solely for use by Licensed Electricians and Certified RV Technicians. No endorsement of technical expertise, arising from the use of the information supplied is either expressed or implied.**



# TABLE OF CONTENTS

## PAGE

<b>1. COVER</b>	<b>6. 120/240VAC WIRING</b>
<b>2. TABLE OF CONTENTS</b>	<b>7. 120/240 VAC CIRCUIT BREAKER EXAMPLES</b>
<b>3. ASSEM. IDENTIFICATION, OPTIONS, &amp; UPGRADE INFO</b>	<b>8. 12 VOLT DC WIRING LABEL</b>
<b>4. TECHNICAL NOTE- MOUNTING REQUIREMENTS</b>	<b>9. 12 VOLT DC WIRING</b>
<b>5. 120/240VAC WIRING LABEL</b>	<b>10. TABLE 310.16 CONDUCTOR AMPACITY CHART</b>

## 5300 Series Assembly Section Identification, & Upgrade Information

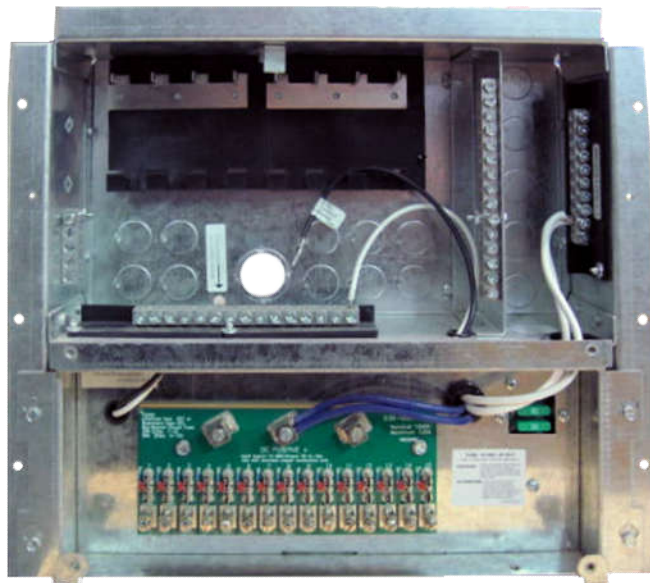

120/240VAC 50A  
Breaker Panel  
Compartment

Load Panel Breaker  
Cover  
(Deadfront)

DC Fuse Panel

\*Cover Plate  
for optional  
TempAssure Module.  
Parallax part # 4400TAU  
Behind DC Fuse Panel



Converter Section



**The 5300 series can be field upgraded to provide temperature compensated output voltage by installing a model 4400TAU TempAssure module and sensor cable.**  
**\*\* Installation instructions are provided inside the kit. \*\***



## Parallax Power Supply Technical Note

### INFORMATION REGARDING MOUNTING CLEARANCES FOR PARALLAX POWER SUPPLY POWER CENTERS.

The Owners Manual states that there must be a minimum of 22 inches of clearance provided to the front of the converter. Also, that adequate room should be left for wire routing and fan air intake located at the rear of the converter. The Owners Manual also states that the converter should not be mounted in zero clearance compartments because overheating and thermal shutdown will result.

#### **Regarding the 22-inch clearance requirement to the front of the converter:**

This statement was made in reference to the NEC article 551-45(b) exception No 1 pertaining to the AC panelboard section of the converter. It simply states that the power center panelboard must have 22 inches of clearance workspace after installation.

The panelboard is considered exposed where the panelboard face is within 2 inches of the finished surface to which it is mounted. A non-locking decorative door may be installed in front of the distribution panelboard however the panelboard must be within 2 inches of a finished surface, not including the door thickness. This is so that the panelboard can be readily accessed when the door is opened, exposing the 22-inch minimum clearance workspace but not allowing enough room between the panelboard and the door for storage.

#### **Regarding adequate room for wire routing and fan air intake:**

Our intent here is to state that there must be enough clearance around the converter to provide adequate intake airflow for cooling the converter system electronics. Also you must leave enough room for the AC and DC field wiring to be installed. In most cases leaving enough room for the field wiring will assure adequate air intake clearance. The main concern seems to be about the clearance to the converter exhaust louvers located in the front of the converter when a decorative door is added over the front of the converter. Because of physical design of the converter the exhaust louvers and the AC panelboard are in the same plane, hence the added door will not be greater than 2 inches from the louvers because of compliance with NEC 551-45 (b) requirement for the panelboard. This will restrict to some degree the exhaust airflow.

The only way to attack this problem is through trial and error. The converter must be placed under the clearance-limiting condition then its operation monitored to verify correct operation. If the converter shuts down due to overheating then the clearance area must be increased to allow proper airflow. The converter has been tested under completely blocked ventilation conditions and will not become a fire hazard but will not hold up to its full rated output load specifications.

Please keep in mind that operating the converter under restricted air flow conditions will elevate the operating temperatures inside the converter and may reduce the life expectancy over time. The converter was designed to operate indefinitely at full load @25c (77f) ambient with the ventilation openings open to the living quarters.

Parallax Power Supply will not be held liable for poor performance or failures of the converter due to restricted air flow installations.



## 5300 Series AC Wiring Label

### 120/240 VAC Wiring Label

(located on back of metal dead front plate  
covering breaker compartment)

**DANGER!** HAZARD OF ELECTRICAL SHOCK OR BURN. TURN OFF POWER SUPPLY FOR THIS EQUIPMENT BEFORE WORKING INSIDE.

**DANGER!** RISQUE DE CHOC ÉLECTRIQUE OU DE BRÛLURE. COUPEZ L'ALIMENTATION DE CET ÉQUIPEMENT AVANT DE TRAVAILLER À L'INTÉRIEUR.

Electrical installation shall comply with the standards and safety requirements of the ANSI/RVIA 12V Standard for Low Voltage Systems in Conversion and Recreational Vehicles, NFPA 70 National Electrical Code and the NFPA 1192 Standard for Recreational Vehicles.

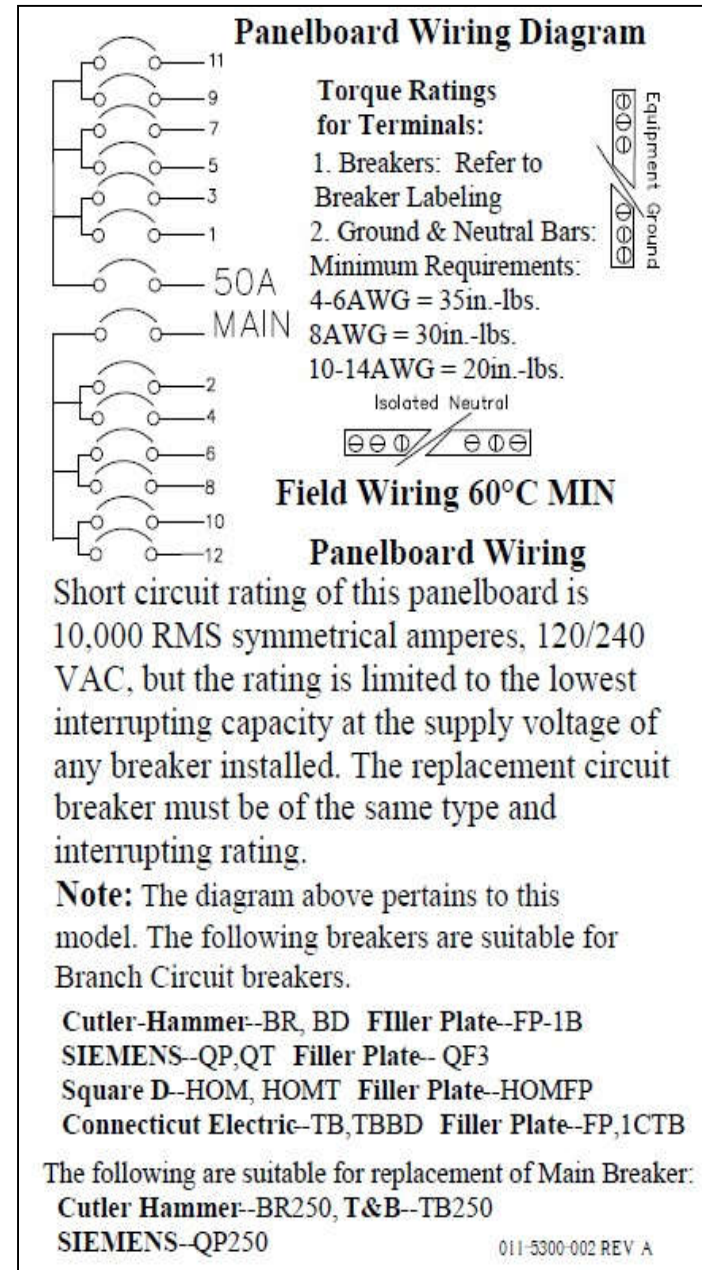

## 5300 Series 120/240VAC Wiring

1. **Horizontal Mounting Only!** Mount the 5300 Series to a vertical surface with the front of the control center open to the living area of the RV. Leave adequate space behind unit for ventilation and wire routing.
2. **Panel rated 120/240V 50 Ampere. Supports a maximum of twelve 120VAC branch circuits (Circuit breakers not supplied).** See AC wiring label for a list of suitable main and branch load circuit breakers. Use suitable filler plates for any unused breaker locations.
3. Install appropriately sized strain relief to provide wire support on all AC or DC Chassis knockouts removed.
4. 120 VAC load breakers amperage rating chosen by AWG wire size used for the load. Connect to (black) load circuit “hot” leads. #14 AWG “Romex” connect to maximum 15 ampere load breaker. #12 AWG “Romex” connect to a maximum 20 ampere load breaker.
5. Connect Shore power “line” conductors (black, red) to a 2-pole 50 ampere maximum main breaker.
6. **NEC requires breaker “hold-down” bracket to secure the 50 ampere 2-pole main breaker.**
7. Shore power and 120 VAC load circuit (white) neutrals (commons) connect to this isolated terminal bar.
8. Shore Line (green conductor) and 120 VAC load circuit bare copper grounds and bonding conductor may only connect to these terminal bars.
9. AC bond routing hole for (# 8 AWG minimum required) AC bonding conductor.
10. Connect converter power “hot” (black) line conductor wire pin to a 20 ampere (maximum) branch load breaker.
11. **Refer to breakers and AC wiring label for terminal bar and circuit breaker torque ratings..**

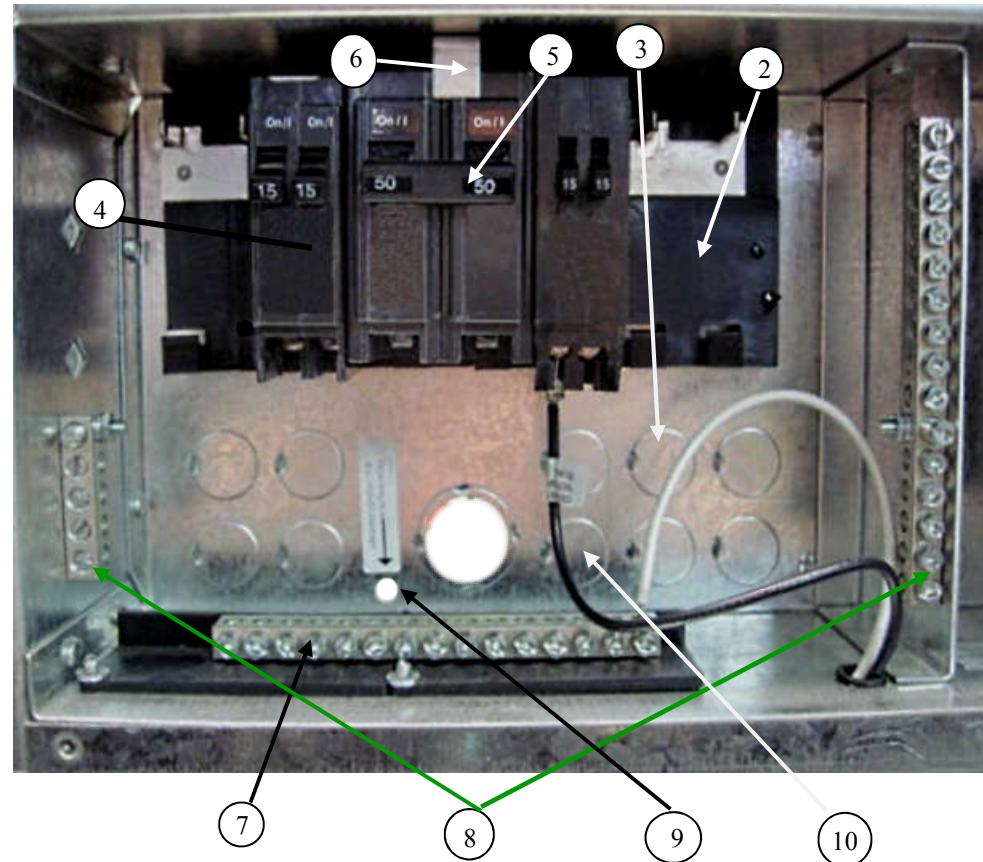

Product shown with Door and dead front plate removed.

**Note- Circuit breakers not supplied with unit.**

**DANGER!** HAZARD OF ELECTRICAL SHOCK OR BURN. TURN OFF POWER SUPPLY FOR THIS EQUIPMENT BEFORE WORKING INSIDE.

**DANGER!** RISQUE DE CHOC ÉLECTRIQUE OU DE BRÛLURE. COUPEZ L'ALIMENTATION DE CET ÉQUIPEMENT AVANT DE TRAVAILLER À L'INTÉRIEUR.

## Examples of Listed Circuit Breaker Types

See AC wiring label for complete list.

### SIEMENS ITE /GOULD

**Type QP 2 Pole  
Plug In**

Requires two 1" spaces  
HACR 120/240VAC  
10,000 AIC

Type suitable for use as  
a main breaker.



### SIEMENS ITE /GOULD

**Type QT Twin Pole-  
Plug In**

Requires One 1" Space  
HACR 120/240VAC  
10,000 AIC



### SQUARE D®

**Type H0MT Twin Pole-  
Plug In**

Requires One 1" Space  
HACR 120/240VAC  
10,000 AIC



### Cutler-Hammer Bryant

**Type BD- Twin Pole-  
Type C Plug In**

Requires One 1" Space  
HACR SWD Rated  
120/240VAC 10,000 AIC





# DC Wiring Label

(located inside outer door)

**A.** Load circuit fuses should be appropriately rated for the safe amperage capacity of the load wiring gauge used.

**B.** DC Positive terminal lugs are electrically connected together and may be used for source DC input positive connections or high current DC positive outputs as desired. If used as an output, an appropriately rated in-line fuse or breaker is required.

**Torque fuse panel connections to specifications stated on the fuse panel wiring label.**

**90 degree Celsius insulation rating minimum required for low voltage wiring in the RV .**

DC branch load fuses not supplied with unit.

Electrical installation shall comply with the standards and safety requirements of the ANSI/RVIA 12V Standard for Low Voltage Systems in Conversion and Recreational Vehicles, NFPA 70 National Electrical Code and the NFPA 1192 Standard for Recreational Vehicles.

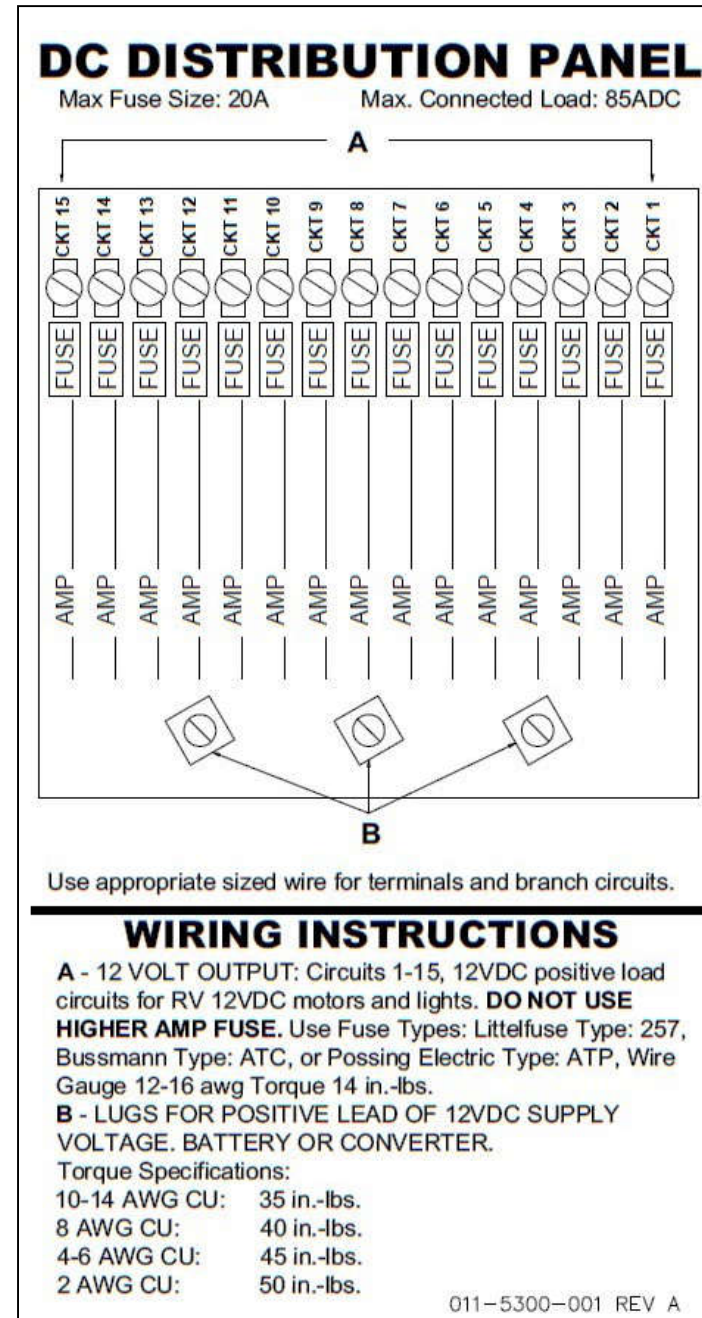



## 5300 Series DC Wiring

1. Converter DC output leads. See Note 2.
2. Lugs (3) for positive DC input of 12 volt supply from the converter or batteries.
3. 12 volt negative terminal bar. Use for negative connection of the converter, 12 volt loads, and the battery system.
4. Converter DC negative output leads. See Note 2.
5. Converter output protection fuses. Use same type and rating. **Do not over-fuse!**
6. 12 Volt branch load circuit positive connection terminals. Fuse each load circuit per current NEC Code (Table 310-16) appropriate to the AWG conductor size and temperature rating of the conductor used. See Note 1.
7. **Refer to AC wiring label on page 5 for terminal bar torque ratings and the DC Distribution panel for wiring lug torque ratings. Tighten all wiring connections to the specified torque values.**

Electrical installation shall comply with the standards and safety requirements of the ANSI/RVIA 12V Standard for Low Voltage Systems in Conversion and Recreational Vehicles, NFPA 70 National Electrical Code and the NFPA 1192 Standard for Recreational Vehicles.

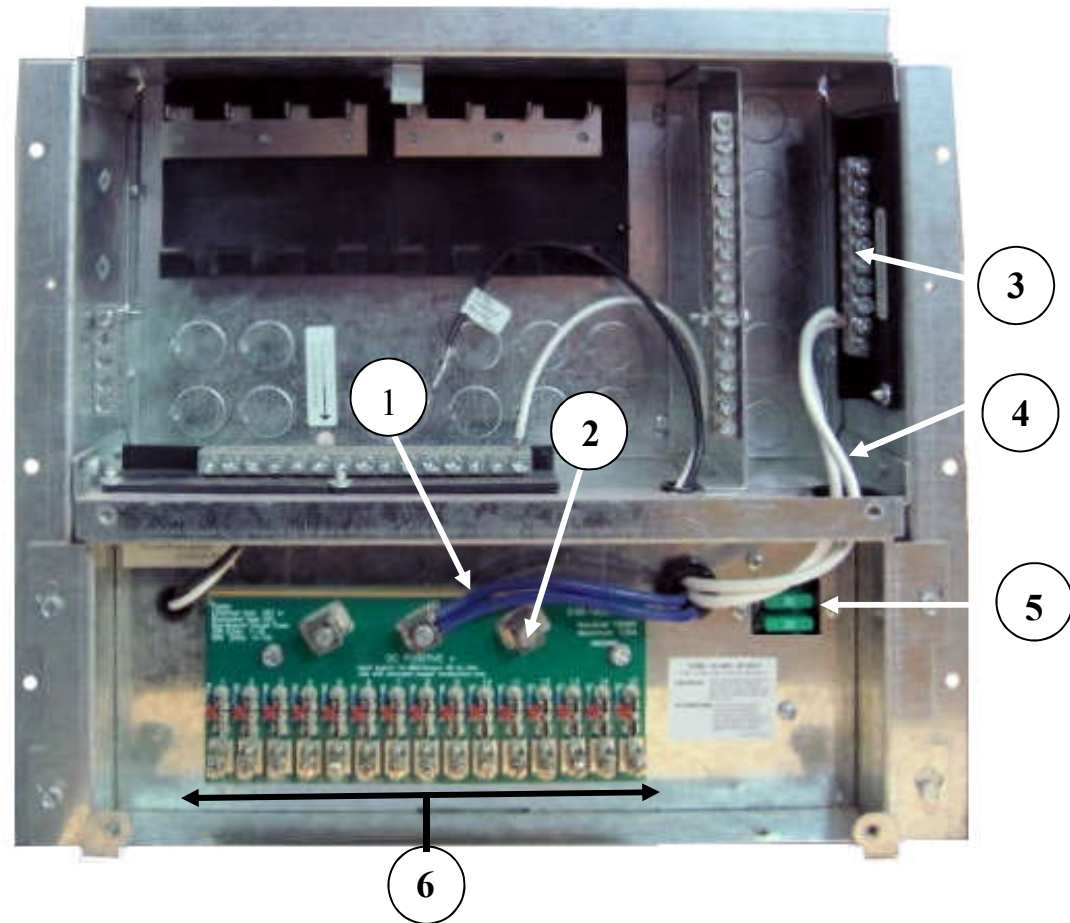

### Notes:

1. DC load circuit fuses not supplied.
2. Converter may have 1 or 2 DC positive and negative output leads depending on the DC output amperage capacity.

## Conductor Ampacity Chart

AWG	Diameter		Turns of wire		Area		Copper resistance <sup>[6]</sup>		NEC copper wire ampacity with 60/75/90°C insulation (A) <sup>[7]</sup>	Approximate stranded metric equivalents
	(inch)	(mm)	(per inch)	(per cm)	(kcmil)	(mm <sup>2</sup> )	(Ω/km)	(Ω/kFT)		
2	0.2576	6.544	3.88	1.53	66.4	33.6	0.5127	0.1563	95 / 115 / 130	
3	0.2294	5.827	4.36	1.72	52.6	26.7	0.6465	0.1970	85 / 100 / 110	196/0.4
4	0.2043	5.189	4.89	1.93	41.7	21.2	0.8152	0.2485	70 / 85 / 95	
5	0.1819	4.621	5.50	2.16	33.1	16.8	1.028	0.3133		126/0.4
6	0.1620	4.115	6.17	2.43	26.3	13.3	1.296	0.3951	55 / 65 / 75	
7	0.1443	3.665	6.93	2.73	20.8	10.5	1.634	0.4982		80/0.4
8	0.1285	3.264	7.78	3.06	16.5	8.37	2.061	0.6282	40 / 50 / 55	
9	0.1144	2.906	8.74	3.44	13.1	6.63	2.599	0.7921		84/0.3
10	0.1019	2.588	9.81	3.86	10.4	5.26	3.277	0.9989	30 / 35 / 40	

7. <sup>^</sup> NFPA 70 National Electrical Code 2008 Edition --- Table 310.16 page 70-148, Allowable ampacities of insulated conductors rated 0 through 2000 volts, 60°C through 90°C, not more than three current-carrying conductors in raceway, cable, or earth (directly buried) based on ambient temperature of 30°C. Extracts from NFPA 70 do not represent the full position of NFPA and the original complete Code must be consulted.