

INSTALLATION INSTRUCTIONS

MODEL 7345RU RETROFIT 45 AMP ELECTRONIC POWER CONVERTER KIT

WARNING: DANGER OF ELECTRICAL SHOCK OR BURNS.

THE INSTALLATION OF THIS RETROFIT SHOULD BE PERFORMED BY A QUALIFIED ELECTRICIAN OR CERTIFIED RV TECHNICIAN. THIS KIT IS DESIGNED FOR REPLACEMENT OF THE PARALLAX, MAGNETEK OR B-W MANUFACTURERS SERIES 6300 MODEL 6345 45 AMP RV POWER CONVERTER, AS AN UPGRADE (**NEC REQUIRES THAT THE INTERNAL WIRING OF THE BATTERY TO THE CONVERTER MUST USE 90°C MINIMUM IF 8 GA CU WIRE IS USED**).

STEP #1-(A) DISCONNECT 120 SHORELINE POWER FROM RV.

(B) MAKE SURE THE ON BOARD GENERATOR (IF EQUIPPED) IS SHUT DOWN.

(C) DISCONNECT RV BATTERY (IES) AT BATTERY.

STEP #2-REMOVE THE FOUR FRONT DOOR #8/32 PHILLIPS HEAD SCREWS SHOWN IN ILL. 1. REMOVE DOOR AND SET ASIDE IN AN AREA WHERE IT WILL NOT BE SCRATCHED OR DAMAGED. DISCARD THE 4 SCREWS. NEW DOOR GROUNDING TYPE SCREWS ARE SUPPLIED.

120 VAC PANELBOARD SECTION

REMOVE THE TWO #10/32 SCREWS SHOWN IN ILL. 2 FROM THE 120 VAC PANELBOARD DEADFRONT AND REMOVE DEAD FRONT. LOCATE THE #14 BLACK AND WHITE 120 VAC FEEDER WIRES COMING UP FROM THE LEFT HAND CORNER OF THE LOWER CONVERTER SECTION. DISCONNECT THE WHITE NEUTRAL WIRE FROM NEUTRAL BAR AND BLACK HOT WIRE FROM THE AC BREAKER THEN PULL BOTH WIRES DOWN INTO LOWER CONVERTER SECTION.

NOTE: THE BLACK WIRE CONNECTED TO THE AC BREAKER MAY HAVE AN ADDITIONAL CIRCUIT CONNECTED TO A PIGTAIL WIRE. IF SO, REMOVE THE YELLOW WIRE NUT FROM THAT BRANCH CIRCUIT BEFORE PULLING WIRES DOWN INTO THE LOWER CONVERTER SECTION.

12 VOLT DC DISTRIBUTION SECTION

REMOVE THE 2 #8 FUSE BLOCK MOUNTING SCREWS SHOWN IN ILL. 2. LEAN FUSE BLOCK FORWARD AND REMOVE THE #10/32 BOLT LOCK WASHER AND NUT ASSEMBLY FROM THE #10 BLUE FEEDER WIRE LOCATED AT THE TOP OF FUSE BLOCK.

REMOVE THE RED #10 WIRE FROM THE REAR OF TERMINAL "C" AND WHITE #10 WIRE FROM THE REAR OF TERMINAL "D". DO NOT DISCONNECT BRANCH CIRCUIT, BATTERY POSITIVE AND NEGATIVE WIRES FROM FRONT OF FUSE BLOCK AT THIS TIME.

PULL RED, WHITE AND BLUE WIRES DOWN INTO LOWER CONVERTER SECTION.

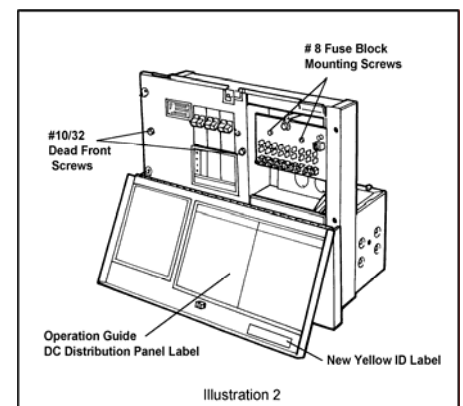
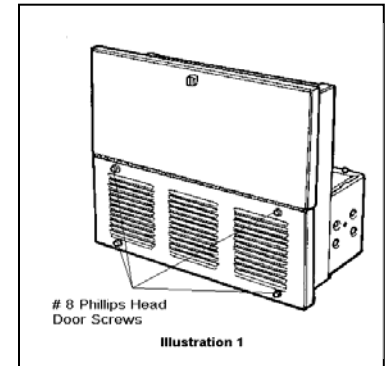

OLD CONVERTER SECTION REMOVAL

REMOVE THE FOUR #6 CONVERTER MOUNTING SCREWS SHOWN IN ILL. 3.
REMOVE THE OLD CONVERTER SECTION BY PULLING STRAIGHT OUT.

NEW CONVERTER SECTION INSTALLATION

STEP #1- ATTACH THE NEW #14 BLACK AND WHITE NEUTRAL AND HOT WIRES SUPPLIED WITH 7345RU AND PLACE THE ¼ INCH QUICK CONNECT ENDS DOWN THROUGH THE PANEL BOARD BUSHING WHERE THE ORIGINAL WIRES ENTERED THE BREAKER COMPARTMENT.

STEP #2- SLIDE THE NEW CONVERTER SECTION INTO THE LOWER SLOT ABOUT HALF WAY IN. ROUTE THE BLACK AND WHITE WIRES ACROSS THE TOP COVER PLATE OF THE CONVERTER SECTION AND DOWN THROUGH THE BUSHING LOCATED IN THE FRONT RIGHT HAND CORNER OF THE CONVERTER SECTION. PLUG THE WHITE WIRE ONTO THE BLADE ON CIRCUIT BOARD MARKED "E1". PLUG THE BLACK WIRE ONTO THE BLADE MARKED "E2". (SEE ILL. 3)

STEP #3- ROUTE THE WIRES ACROSS THE TOP COVER PLATE UNDER THE PLASTIC WIRE STRAPS PULLING ANY SLACK BACK OUT OF THE CONVERTER SECTION.

STEP #4- SLIDE CONVERTER SECTION THE REST OF THE WAY IN AND SECURE WITH THE ORIGINAL #6 SCREWS. ROUTE THE #10 GA BLUE AND WHITE WIRES SUPPLIED ON CONVERTER SECTION UP THROUGH RIGHT FRONT BUSHING AND INTO THE 12 VOLT FUSE BLOCK COMPARTMENT.

NOTE: THERE IS NO RED #10 GA WIRE USED IN THE NEW CONVERTER SECTION INSTALLATION.

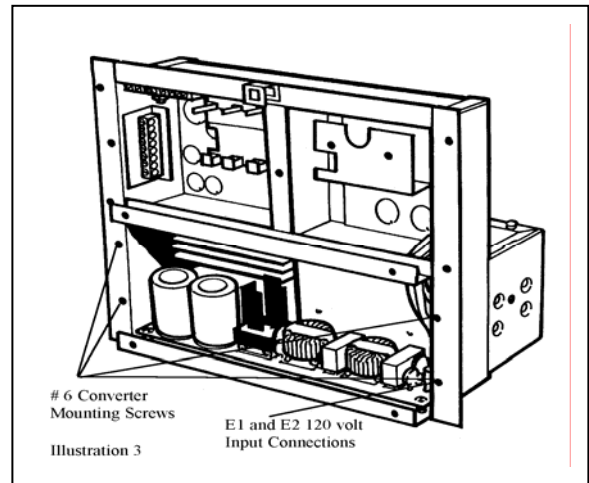

NEW 12 VOLT FUSE BLOCK INSTALLATION

STEP #1- ATTACH THE NEW BLUE #10 GA WIRE TO THE NEW FUSE BLOCK IN THE EYELET LOCATED DIRECTLY ABOVE THE MAIN FUSE CLIPS (SEE ILL. 4) WITH THE HARDWARE USED ON ORIGINAL FUSE BLOCK. TIGHTEN SECURELY. VISUALLY INSPECT THAT THE WIRE TERMINAL IS NOT GROUNDED TO FUSE BLOCK MOUNTING BRACKET.

STEP #2- ATTACH THE NEW #10 GA WHITE TO REAR OF TERMINAL "D". (SEE ILL. 4) TIGHTEN SECURELY.

STEP #3- REATTACH FUSE BLOCK WITH ORIGINAL #8 SCREWS REMOVED FROM OLD FUSE BLOCK.

STEP #4- INSERT THE TWO 30 AMP FUSES SUPPLIED WITH RETROFIT KIT INTO THE MAIN FUSE SLOTS AT THE TOP CENTER OF THE NEW FUSE BLOCK.

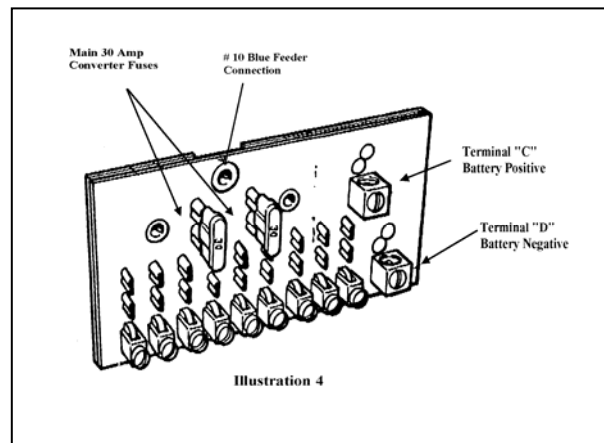

REWIRING 12 VOLT FUSE BLOCK BRANCH AND BATTERY FEEDER CIRCUITS

NOW THAT THE NEW FUSE BLOCK IS WIRED FROM THE BACK SIDE AND MOUNTED, THE LAST STEP IS TO MOVE THE WIRING FROM THE FRONT OF THE ORIGINAL FUSE BLOCK TO THE NEW BLOCK.

PLEASE NOTE: WITH THE NEW 7345RU ELECTRONIC CONVERTER, THERE IS NO NEED TO SEPARATE ACCESSORY CIRCUITS FROM THE LIGHTING AND MOTOR CIRCUITS TO ACHIEVE THE FILTERED ACCESSORY AND UNFILTERED LIGHTING AND MOTOR CIRCUITS. ALL NINE BRANC CIRCUITS ON THE NEW FUSE BLOCK ARE CLEAN FILTERED AND REGULATED 12 VOLT DC OUTPUTS. THIS HOLDS TRUE WITH OR WITHOUT A BATTERY CONNECTED.

STEP #1- FROM LEFT TO RIGHT, BEGIN REMOVING EACH BRANCH CIRCUIT WIRE FROM ORIGINAL FUSE BLOCK AND ATTC H TO THE CORRESPONDING BRANCH ON THE NEW BLOCK. IMPORTANT: EACH TIME A CIRCUIT IS MOVED, BE SURE TO MOVE THE FUSE THAT PROTECTED THAT CIRCUIT TO THE CORRESPONDING FUSE SLOT ON THE NEW BLOCK. DO THIS FOR ALL BRANCH CIRCUITS USED.

STEP #2- REMOVE THE WIRE FROM TERMINAL "D" (BATTERY NEGATIVE) ON OLD FUSE BLOCK. (SEE OLD LABEL ON THE DOOR THAT YOU REMOVED AND SET ASIDE EARLIER FOR LOCATION). REATTACH WIRE TO TERMINAL "D" ON NEW BLOCK. (SEE ILL. 4)

STEP #3- REMOVE THE WIRE FROM TERMINAL "C" (BATTERY POSITIVE) ON OLD FUSE BLOCK. AGAIN LOOK AT OLD LABEL ON DOOR FOR LOCATION. REATTACH WIRE TO TERMINAL "C" ON NEW FUSE BLOCK. (SEE ILL. 4)

REWIRING 120 VAC PANELBOARD

RECONNECT THE NEW WHITE #14 GA NEUTRAL WIRE TO THE NEUTRAL BAR WHERE THE ORIGINAL WIRE WAS CONNECTED. RECONNECT NEW BLACK #14 GA "HOT" FEEDER WIRE TO THE SAME BREAKER THAT THE ORIGINAL WIRE WAS CONNECTED. RECONNECT THE PIGTAIL BRANCH CIRCUIT (IF USED) WITH YELLOW WIRE NUT.

AT THIS POINT IT IS RECOMMENDED THAT YOU CHECK ALL CONNECTIONS TO MAKE SURE ALL STRANDS ARE INSIDE THE TERMINALS AND SCREWS ARE DOWN TIGHT ON THE WIRE.

REPLACE PANEL BOARD DEAD FRONT WITH ORIGINAL SCREWS.

ADDING NEW LABELS TO FRONT DOOR

IMPORTANT: COPY DC DISTRIBUTION BRANCH CIRCUIT INFORMATION TO THE NEW LABEL LEGEND.

REPLACE OLD OPERATION GUIDE/DC DISTRIBUTION PANEL LABEL ON DOOR WITH THE NEW LABEL SUPPLIED. (PN# 51092338-000) (SEE ILL. 2)

ADD THE YELLOW ID LABEL SUPPLIED (PN# 51092485-000) DIRECTLY BELOW THE DISTRIBUTION PANEL LABEL. (SEE ILL. 2)

REPLACE FRONT DOOR WITH THE NEW SERRATED GROUNDING SCREWS PROVIDED.

BATTERY (IES) RECONNECTION

CAUTION: OBSERVE BATTERY POLARITY. REVERSE POLARITY WILL BLOW THE TWO 30 AMP MAIN FUSES AND POSSIBLY DAMAGE CONVERTER.

CLEAN BATTERY POSTS AND RECONNECT BATTERY WIRES.

PLUG IN 120 VAC SHORELINE AND MAKE SURE THAT ALL AC BREAKERS ARE ON.

YOUR INSTALLATION OF THE RETROFIT CONVERTER IS NOW COMPLETE.

GENERAL

YOUR MODEL 7345RU POWER CONVERTER IS THE RESULT OF THE TECHNOLOGY GAINED DURING THE RECENT EXPLOSION OF HOME COMPUTERS AND MODERN METHODS IN MANUFACTURING OF HI POWER SWITCHING DEVICES AT AN AFFORDABLE PRICE.

ELECTRONIC SWITCH MODE POWER SUPPLIES ARE NOT NEW AS FAR AS APPLICATIONS IN THE MILITARY AND INDUSTRIAL CONTROL SYSTEMS WHERE LIGHTWEIGHT QUITE EFFICIENT OPERATION WAS A PREMIUM AND COST WAS NOT THE LIMITING FACTOR. UNTIL RECENTLY, THE COST OF ELECTRONIC POWER CONVERTERS IN THE RV INDUSTRY PROHIBITED MOST MANUFACTURERS FROM CONSIDERING THEIR USE. AS TECHNOLOGY HAS MOVED FORWARD, THE MANUFACTURERS OF 12-VOLT APPLIANCES ENERGY MANAGEMENT SYSTEMS, HOME ENTERTAINMENT EQUIPMENT AND NUMEROUS OTHER DEVICES IN THE RV INDUSTRY HAVE DEMANDED MORE FILTERED AND REGULATED 12-VOLT POWER.

PARALLAX HAS MOVED FORWARD IN SUPPLYING THE RV OWNER WITH AN ECONOMICAL ALTERNATIVE. ALTHOUGH SLIGHTLY MORE EXPENSIVE THAN THE TRADITIONAL LINEAR CONVERTERS, THE PARALLAX 7345RU POWER CONVERTER UPGRADE SUPPLIES THE ENTIRE RV WITH FILTERED WELL-REGULATED 12-VOLT POWER. THE 7300 SERIES IS AN EXCELLENT BATTERY CHARGER ALLOWING THE FULL RATED OUTPUT TO CHARGE YOUR BATTERY (IES) IF NEEDED, BUT DOES NOT REQUIRE A BATTERY TO BE INSTALLED IN YOUR RV.

PARALLAX WARRANTY STATEMENT

PARALLAX WARRANTS ITS PRODUCTS TO BE FREE FROM DEFECTS IN MATERIAL OR WORKMANSHIP UNDER NORMAL USE AND SERVICE AND LIMITS THE REMEDIES TO REPAIR OR REPLACEMENT.

THIS WARRANTY EXTENDS FOR TWO YEARS FROM THE DATE OF PURCHASE AND IS VALID ONLY TO THE ORIGINAL OWNER AND WITHIN THE CONTINENTAL LIMITS OF THE UNITED STATES AND CANADA.

IF A PROBLEM SHOULD OCCUR WITH YOUR PARALLAX RETROFIT CONVERTER WITHIN THE FIRST TWENTY-FOUR MONTHS AFTER PURCHASE, PLEASE CONTACT A DEALER THAT HANDLES WARRANTY ON YOUR BRAND OF RV. NO USER SERVICABLE PARTS INSIDE.

CUSTOMER SERVICE DEPARTMENT
425 Sycamore
Anderson, IN. 46016

TELEPHONE: 800 / 443-4859

